

FM10Q-V

10.4" Android Forklift Computers with Qualcomm® Snapdragon™ 660



KEY FEATURES

- Qualcomm Snapdragon™ 660 octa-core, 2.2 GHz CPU, Android forklift computers
- 10.4" 1024 x 768 Panel with PCAP touchscreen
- IP65 waterproof and dustproof
- Wide power input 9-36V DC with ignition
- Wide range operating temperature
- Support VESA Mount



SPECIFICATIONS

Display			
Resolution	1024x768	Size	10.4 inches
Contrast Ratio	1200:1	Panel Brightness	400 nits 800 nits(Optional)
View Angles	88,88,88,88	Type	Projected Capacitive Multi Touch
Touch Mode	With Stylus Support With Gloves Support		
System Specification			
Processor	Qualcomm® Snapdragon™ 660 (Octa-Core 2.2 GHz)	Memory	3GB
Storage	32GB	Operating System	Android 9.0
WLAN	Support	BT	Support
WWAN	4G/LTE (Optional)	GNSS	GPS/GLONASS (Optional)
Sensors	G-Sensor, Temp. Sensor		
Camera			
Front Camera	2MP Camera		
Mechanical			
Dimension	268 x 214 x 51 mm	Weight	2.4 kg
Mounting	RAM Mount/ VESA Mount	Cooling System	Fanless Design
IO Ports			
USB Port	1 x USB 3.0 Type C (OTG) 1 x USB 2.0 Port	Serial Port	2 x RS232/422/485 (Default RS232)
SD Card Slot	1 x Micro SD Card Slot	SIM Card Slot	1 x Dual-Nano SIM Card Slot
Audio	1 x Audio(Mic in or Line Out) either one with DIDO (Optional)	LAN	1 x Gigabit LAN port PSE (IEEE 802.3at 30W) (Optional)
Indicator	4 x LED Indicator (Wi-Fi, BT, UPS battery, Screen Blanking, Heater)	DIDO	1 x DIDO (2XDI ; 2XDO) either one with Audio (Optional)
CANBUS	1 x CANBus (Optional)		
Environment			
Operating Humidity	5% to 95% RH, Non-Condensing	Operating Temperature	-30°C to 50°C
Storage	-30°C to 60°C	Shock	MIL-STD-810H Method 516.8 Procedure I

Temperature			
Vibration	MIL-STD-810H Method 514.8 Procedure I	IP rating	IP65, Compliance IEC60592
Impact	Support EN62262 IK07 Rating	ESD	Compliant with EN 61000-4-2, Enhanced ESD to ±8kV Direct & ±15kV Air
Certification			
Certification	CE, FCC		
Control			
Button	1 x Power Button, 6 x Function Button (Programmable Function Key Configured by Winset)		
Power			
Battery	400mAh UPS Battery for 20 minutes backup (Optional)	Power Rating	10V~60V with ignition control
Security Function			
SOTI MobiControl	SOTI MobiControl Compliance		
Accessory			

Accessory	5M Power Cable with Fuse Kit 0.15M Power Converter Cable DC Jack Power Cable 84W Adapter with power cable Quick Start Guide	Optional Accessory	Stylus Kit + Screw 1.8M RS232 Cable 2M IP65 LAN Cable GPS & LTE 2M Combo Antenna(VM240) GPS & LTE 5M Combo Antenna (VM9C) GPS & LTE Magnetic Combo Antenna (VM10S) GPS Antenna WWAN Antenna 2M Waterproof USB Type-A to A Cable Cable Clamp Kit COM Port + CANBus Cable COM Port + DIDO Cable
------------------	---	---------------------------	--

DIMENSIONS UNIT:MM

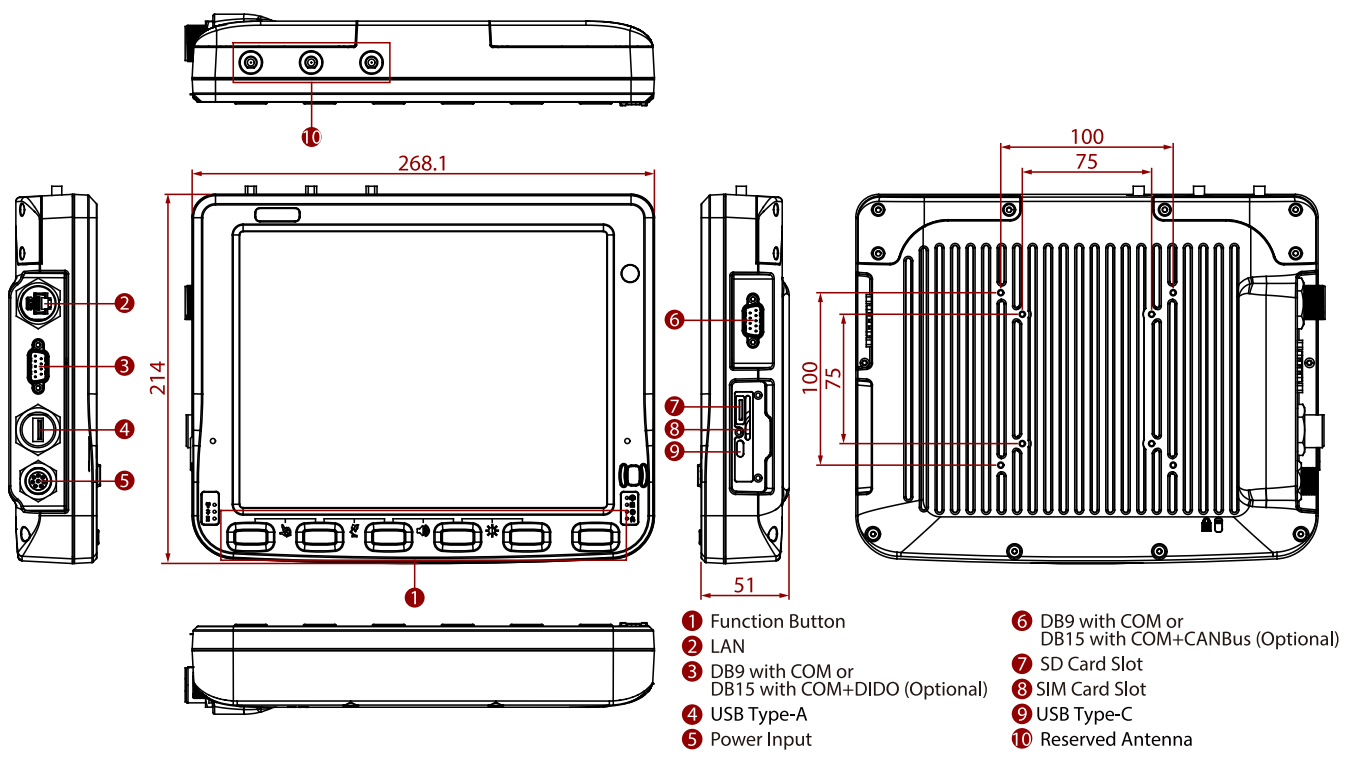

NOTE

1. Total usable memory will be less dependent upon actual system configuration.
2. CANBus and audio are mutually exclusive.
3. The heater is a customized feature available by request.
4. SOTI is available upon request.
5. Length measurements do not include protrusions. Weight varies with options.
6. Measured at dimming LCD brightness. Varies depending on the usage conditions, or when an external device is attached.
7. Accessories may vary depending on your configuration.
8. Two Wi-Fi antennas are included in the standard package.
9. The product shown in this datasheet is a standard model. For diagrams that contain customized or optional I/O, please contact the Winmate Sales Team for more information.
10. Please order one bracket for one antenna. For example, if you plan to use two antennas, please order two brackets.
11. Notice that only one antenna is included in the package. If you plan to use the WWAN function please order two WWAN antennas.
12. This is a simplified drawing and some components are not marked in detail.
13. The UPS battery is only expect to use for backup under system low loading and without I/O function.